

AXIAL TOOLHOLDERS

PER VDI 3425

DIN 69880

Form C1

RIGHT HAND

Part No.	D	B1	B2	B3	H1	H5	H6	L1	L2
513020	30	70	35	17	3/4"	28	38	70	10
514025	40	85	42.5	20.5	1"	32.5	48	85	12.5
515032	50	100	50	25.5	1-1/4"	35	60	100	16

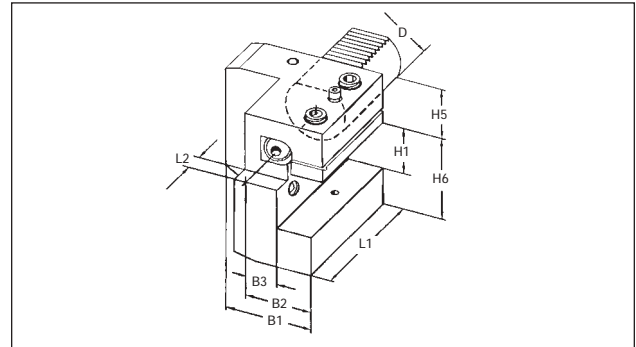

Form C2

LEFT HAND

Part No.	D	B4	B5	B6	H1	H5	H6	L1	L2
523020	30	76	41	23	3/4"	28	38	70	10
524025	40	90	47.5	25.5	1"	32.5	48	85	12.5
525032	50	105	55	30.5	1-1/4"	35	60	100	16

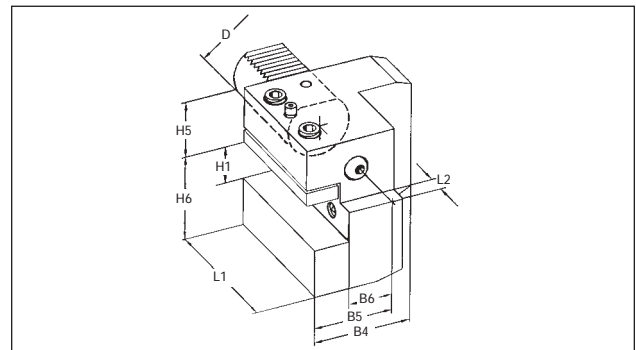

Form C3

RIGHT HAND REVERSE

Part No.	D	B1	B2	B3	H1	H6	H7	L1	L2
533020	30	70	35	17	3/4"	38	35	70	10
534025	40	85	42.5	20.5	1"	48	42.5	85	12.5
535032	50	100	50	25.5	1-1/4"	60	50	100	16

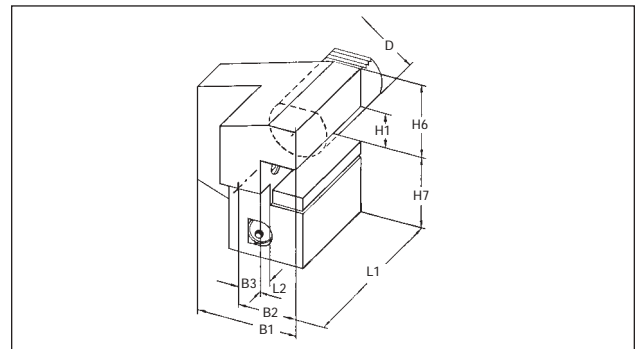

Form C4

LEFT HAND REVERSE

Part No.	D	B4	B5	B6	H1	H6	H7	L1	L2
543020	30	76	41	23	3/4"	38	35	70	10
544025	40	90	47.5	25.5	1"	48	42.5	85	12.5
545032	50	105	55	30.5	1-1/4"	60	50	100	16

