

VDI TOOLING

LONG RADIAL OVERHEAD TOOLHOLDERS

PER VDI 3425

DIN 69880

Form B5

RIGHT HAND LONG

Part No.	D	B1	B2	B3	H1	H5	H6	L1	L2
473020	30	100	65	10	3/4"	28	38	22	40
474025	40	118	75.5	12.5	1"	32.5	48	22	44
475032	50	130	80	16	1-1/4"	35	60	30	55

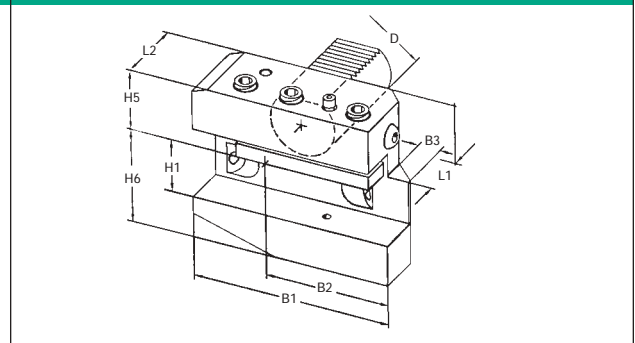

Form B6

LEFT HAND LONG

Part No.	D	B1	B2	B3	H1	H5	H6	L1	L2
483020	30	100	65	10	3/4"	28	38	22	40
484025	40	118	75.5	12.5	1"	32.5	48	22	44
485032	50	130	80	16	1-1/4"	35	60	30	55

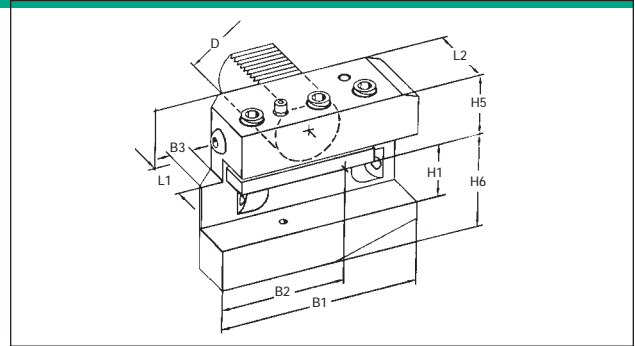

Form B7

RIGHT HAND LONG REVERSE

Part No.	D	B1	B2	B3	H1	H6	H7	L1	L2
493020	30	100	65	10	3/4"	38	35	22	40
494025	40	118	75.5	12.5	1"	48	42.5	22	44
495032	50	130	80	16	1-1/4"	60	50	30	55

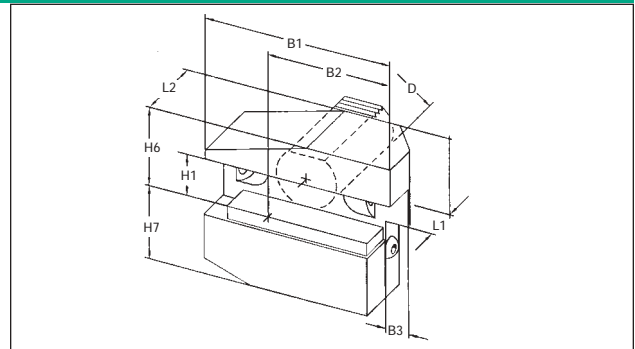

Form B8

LEFT HAND LONG REVERSE

Part No.	D	B1	B2	B3	H1	H6	H7	L1	L2
503020	30	100	65	10	3/4"	38	35	22	40
504025	40	118	75.5	12.5	1"	48	42.5	22	44
505032	50	130	80	16	1-1/4"	60	50	30	55

