

STANDARD RADIAL OVERHEAD TOOLHOLDERS

PER VDI 3425

DIN 69880

Form B1 RIGHT HAND SHORT

Part No.	D	B1	B2	B3	H1	H5	H6	L1	L2
433020	30	70	35	10	3/4"	28	38	22	40
434025	40	85	42.5	12.5	1"	32.5	48	22	44
435032	50	100	50	16	1-1/4"	35	60	30	55

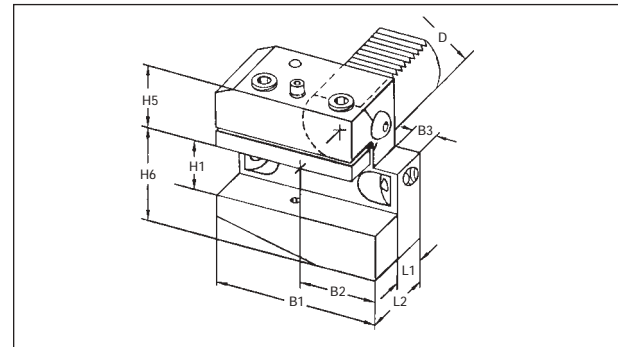

Form B2 LEFT HAND SHORT

Part No.	D	B1	B2	B3	H1	H5	H6	L1	L2
443020	30	70	35	10	3/4"	28	38	22	40
444025	40	85	42.5	12.5	1"	32.5	48	22	55
445032	50	100	50	16	1-1/4"	35	60	30	55

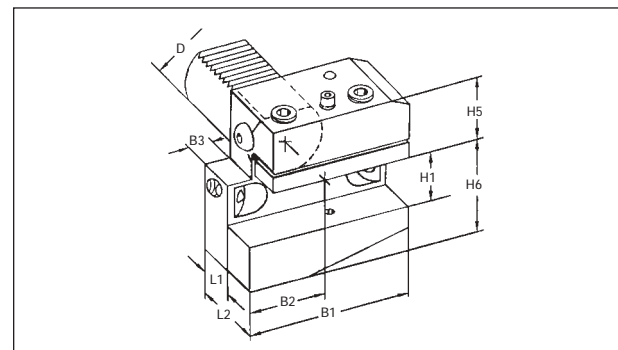

Form B3 RIGHT HAND SHORT REVERSE

Part No.	D	B1	B2	B3	H1	H6	H7	L1	L2
453020	30	70	35	10	3/4"	38	35	22	40
454025	40	85	42.5	12.5	1"	48	42.5	22	44
455032	50	100	50	16	1-1/4"	60	50	30	55

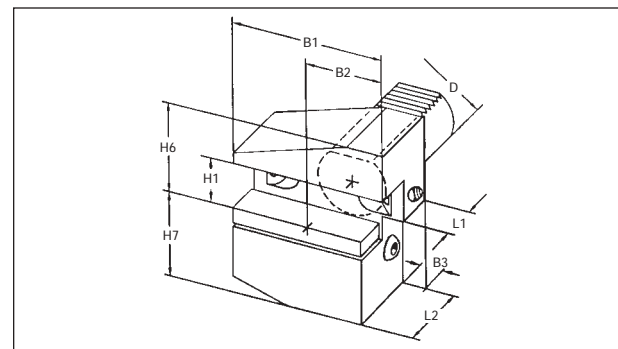

Form B4 LEFT HAND SHORT REVERSE

Part No.	D	B1	B2	B3	H1	H6	H7	L1	L2
463020	30	70	35	10	3/4"	38	35	42	40
464025	40	85	42.5	12.5	1"	48	42.5	22	44
465032	50	100	50	16	1-1/4"	60	50	30	55

